



CA-BA



CA-PA



TALA



VR-SE



MAHE



MARE / MARI



PCU



ES-DR / ES-DA2



AB-TA / AB-TA B  
/ AB-TA A2



AB-TG



PF-ZN / PF-A4



AB-TR



AB-FP



AB-FC



AB-PM7



TM-VR



MAMH



UN-CO



CO-AR

**CARACTERISTICAS**

- Versatilidad en métricas y componentes
- Pletina de cuelgue con doble taladro para una mejor instalación.
- Manguitos de unión de varillas para aplicación de grandes recorridos (locales comerciales, etc.)
- Distintas soluciones de fijación al techo: palomillas, tacos de latón, cabezas basculantes.
- Acabados en cincado, galvanizado o inoxidable (según elementos)

**MATERIAL BASE**

















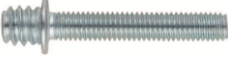







**EJEMPLOS DE APLICACION**



## 1.GAMA

ITEM	DENOMINACION	FOTO	MATERIAL	RECUBRIMIENTO
1	CA-BA		Acero EN10130-DC01+A-m	 Cincado $\geq 5\mu\text{m}$ ISO 4042 A2J
2	CA-PA		Acero SAE 1010	 Cincado $\geq 5\mu\text{m}$ ISO 4042 A2J
3	TALA		Latón T-0T58 Pb UNI 5705	 Latón
4	VR-SE		Acero clase 4.8 ISO 898-1	 Cincado $\geq 5\mu\text{m}$ ISO 4042 A2J
5	MAHE		Acero SAE J403 1008	 Cincado $\geq 5\mu\text{m}$ ISO 4042 A2J
6	MARE		Acero SAE J403 1008	 Cincado $\geq 5\mu\text{m}$ ISO 4042 A2J
7	MARI		Acero A2-70 UNE-EN ISO 3506-1	 Acero A2-70
8	PCU		Acero EN10142-DX51D+Z140-M-B-O	 Cincado $\geq 5\mu\text{m}$ ISO 4042 A2J
9	ES-DR		Acero SAE J403 1008	 Cincado $\geq 5\mu\text{m}$ ISO 4042 A2J
10	ES-DA2		Acero A2-70 UNE-EN ISO 3506-1	 Acero A2-70
11	AB-TA		Acero clase 5.6 ISO 898-1	 Cincado $\geq 5\mu\text{m}$ ISO 4042 A2J
12	AB-TA B		Acero clase 5.6 ISO 898-1	 Bicromatado $\geq 5\mu\text{m}$ ISO 4042 A2J
13	AB-TA A2		Acero A2-70 UNE-EN ISO 3506-1	 Acero A2-70

ITEM	DENOMINACION	FOTO	MATERIAL	RECUBRIMIENTO
14	AB-TG		Acero SAE J403 1023	 Cincado $\geq 5\mu\text{m}$ ISO 4042 A2J
15	PF-ZN		Acero S235R	 Cincado $\geq 5\mu\text{m}$ ISO 4042 A2J
16	PF-A4		Acero A4-70 UNE-EN ISO 3506-1	 Acero A4-70
17	AB-TR		Acero C1008	 Cincado $\geq 5\mu\text{m}$ ISO 4042 A2J
18	AB-FP		Acero C1008	 Cincado $\geq 5\mu\text{m}$ ISO 4042 A2J
19	AB-FC		Acero C1008	 Cincado $\geq 5\mu\text{m}$ ISO 4042 A2J
20	AB-PM7		Acero Q195	 Cincado $\geq 5\mu\text{m}$ ISO 4042 A2J
21	TM-VR		Acero C1008	 Cincado $\geq 5\mu\text{m}$ ISO 4042 A2J
22	MAMH		Acero Q195	 Cincado $\geq 5\mu\text{m}$ ISO 4042 A2J
23	UN-CO		Acero S235R	 Cincado $\geq 5\mu\text{m}$ ISO 4042 A2J
24	CO-AR		Acero Q195	 Cincado $\geq 5\mu\text{m}$ ISO 4042 A2J

## 2. DATOS DE INSTALACION

### 2.1 CA-BA

#### Cabeza basculante



#### Propiedades



Acero

Recubrimiento  
cincado

Patentado

#### Dimensiones

#### Datos de Instalación

CODIGO		CABA004	CABA005	CABA006	CABA008	CODIGO		CABA004	CABA005	CABA006	CABA008
A: $\varnothing$ rosca	[mm]	M4	M5	M6	M8	d $\varnothing$ : diámetro broca	[mm]	14	14	16	20
B: longitud total	[mm]	65	65	70	80	h: profundidad cavidad $\geq$	[mm]	70	70	75	85
C: Altura	[mm]	10.7	10.7	12.0	16.8	Carga a tracción recomendada(N <sub>recom</sub> )	[N]	250	300	350	450
D: anchura	[mm]	7.7	7.7	9.0	12.2						
Varilla roscada		975ZM04	975ZM05	975ZM06	975ZM08						

#### PLANO

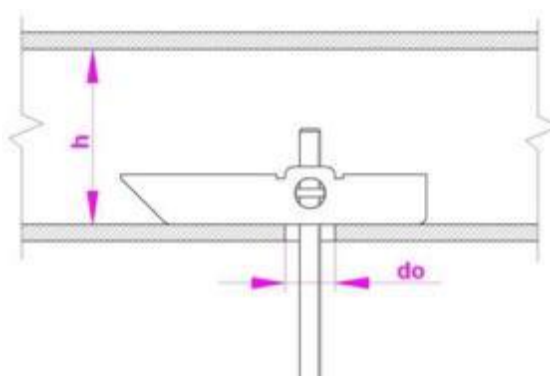
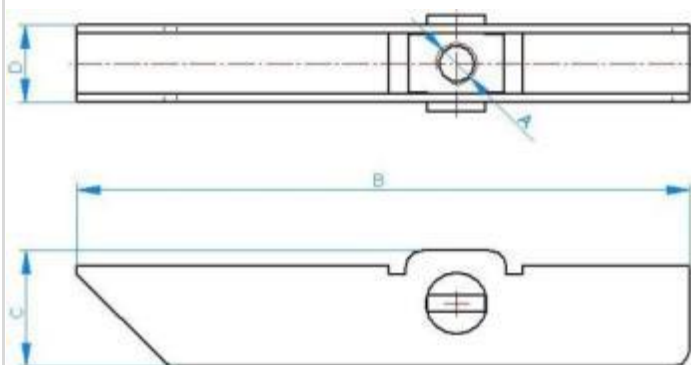

**2.2 CA-PA**

**Cabeza palomilla**



**Propiedades**



Acero

Recubrimiento  
cincado

Patentado

**Dimensiones**

**Datos de Instalación**

CODIGO		CAPA004	CAPA005	CAPA006	CAPA008	CODIGO		CAPA004	CAPA005	CAPA006	CAPA008
A: Ø rosca	[mm]	M4	M5	M6	M8	d0: diámetro broca	[mm]	12	15	18	22
B: longitud total	[mm]	39	50	55	76	h: profundidad cavidad ≥	[mm]	26	33	37	54
C: Altura	[mm]	10	12	14	16	Carga a tracción recomendada(N <sub>recom</sub> )	[N]	95	115	130	140
D: anchura	[mm]	9	12	15	17						
Varilla roscada		975ZM04	975ZM05	975ZM06	975ZM08						

**PLANO**

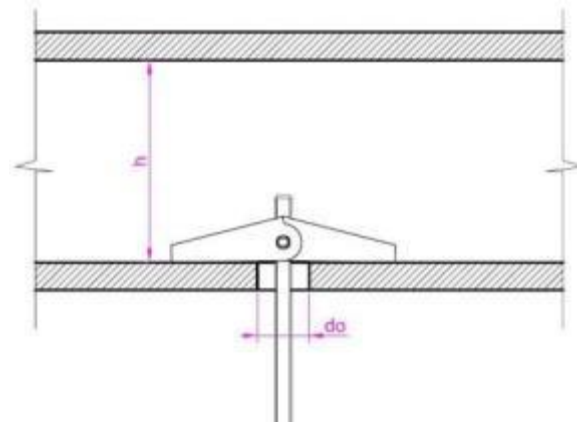
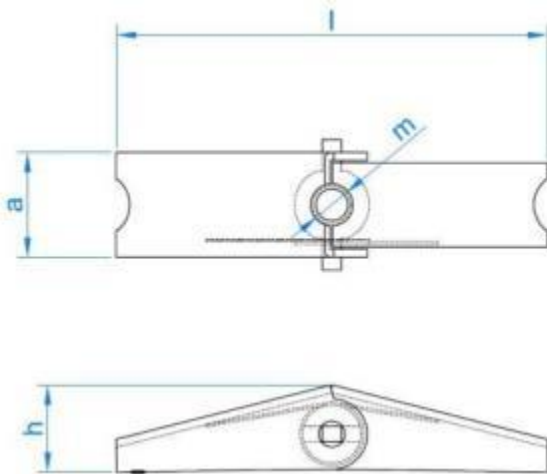

## 2.3 TALA

### Taco de latón



#### Propiedades



Latón

#### Dimensiones

CODIGO		TALA532	TALAM04	TALAM05	TALAM06	TALAM08	TALAM10	TALAM12
di: diámetro rosca interior	[mm]	W5/32	M4	M5	M6	M8	M10	M12
dp: diámetro exterior	[mm]	5	5	6	8	10	12	15
l: longitud anclaje	[mm]	16	16	18	23	28	34	38

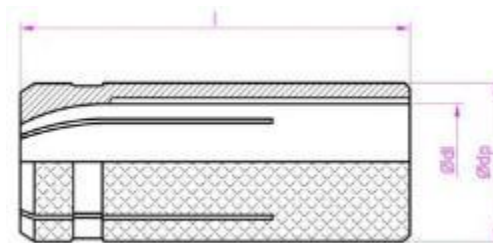

#### Datos de Instalación

CODIGO		TALA532	TALAM04	TALAM05	TALAM06	TALAM08	TALAM10	TALAM12
Ø varilla roscada	[mm]	W5/32	M4	M5	M6	M8	M10	M12
Ø broca taladro	[mm]	5	5	6	8	10	12	15
Profundidad taladro ≥	[mm]	20	20	22	28	33	40	45
Profundidad anclaje ≥	[mm]	16	16	18	23	28	34	38
Profundidad de roscado	[mm]	14	14	16	21	26	32	36
Espesor material base ≥	[mm]	25	25	30	35	40	45	50
Carga tracción recomendada	[N]	600	600	700	1000	1500	2100	3200

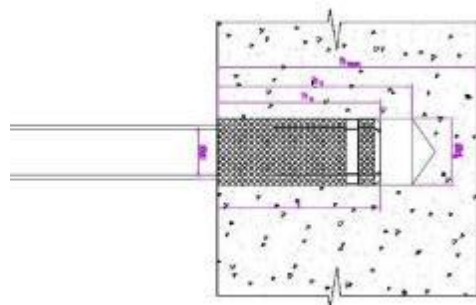

Procedimiento de instalación

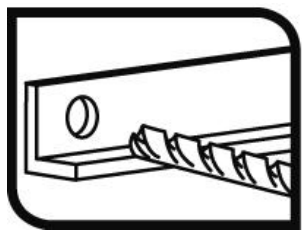

Realizar un taladro en el material base del diámetro y profundidad especificados.

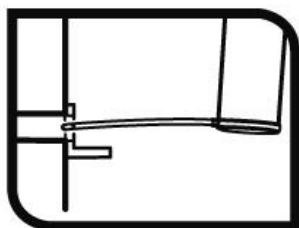

Limpiar el taladro de restos de polvos y fragmentos de taladrado

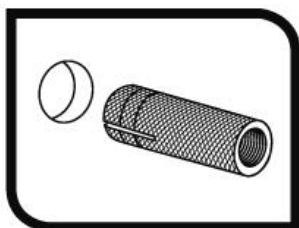

Insertar el taco de latón en el taladro. Si fuese necesario utilizar el martillo

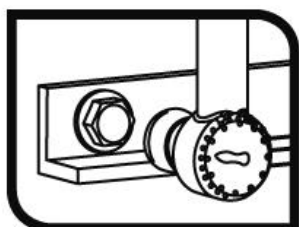

Roscar la varilla en el taco de latón la profundidad indicada en la tabla. Una profanidad escasa puede dar lugar a una menor resistencia del taco de latón; una profanidad excesiva puede provocar la rotura del taco de latón, incluso sin aplicar ninguna carga

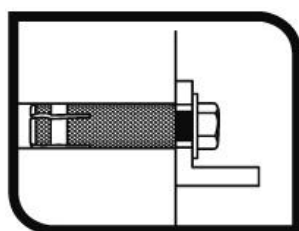



## 2.4 VR-SE

### Espárrago separador



#### Propiedades



Acero

Recubrimiento cincado

#### Dimensiones

#### Plano

CODIGO		VRSE06020	VRSE06030	VRSE08020	VRSE08030	VRSE10030	VRSE12030
M: $\varnothing$ rosca	[mm]	M6	M6	M8	M8	M10	M12
L: longitud total	[mm]	20	30	20	30	30	30



## 2.5 MAHE

### Manguito de conexión hexagonal\*



#### Propiedades



Acero

Recubrimiento cincado

#### Dimensiones

#### Plano

CODIGO	MAE0620	MAE0630	MAE0830	MAE1030	MAE1235	MAE1650	MAE2060
$\varnothing$ d: rosca [mm]	M6	M6	M8	M10	M12	M16	M20
m: longitud total [mm]	20	30	25	30	35	50	60
s: llave de tuerca	10	10	11	13	17	24	30
Varilla roscada	975ZM06	975ZM06	975ZM08	975ZM10	975ZM12	975ZM16	975ZM20

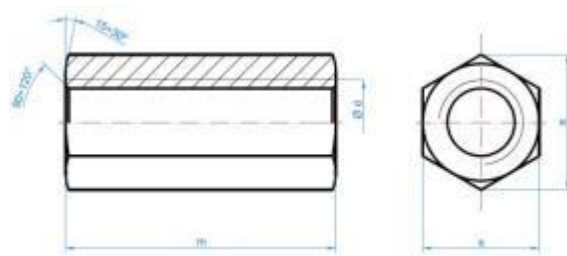

\*resistencia equivalente a un tornillo 6.8



**2.6 MARE**

**Manguito de conexión cilíndrico\***



**Propiedades**



Acero

Recubrimiento cincado

**Dimensiones**

CODIGO		MAR5322	MAR0420	MAR0620	MAR0630	MAR0825	MAR0830	MAR1030	MAR1235	MAR1650
Ød1: rosca	[mm]	M4	M6	M6	M6	M8	M8	M10	M12	M16
m: longitud total	[mm]	20	20	20	30	25	30	30	35	50
Ød2: diámetro exterior	[mm]	7	7	10	10	11	11	13	15	22
Varilla roscada		-	975ZM04	975ZM06	975ZM06	975ZM08	975ZM08	975ZM10	975ZM12	975ZM16

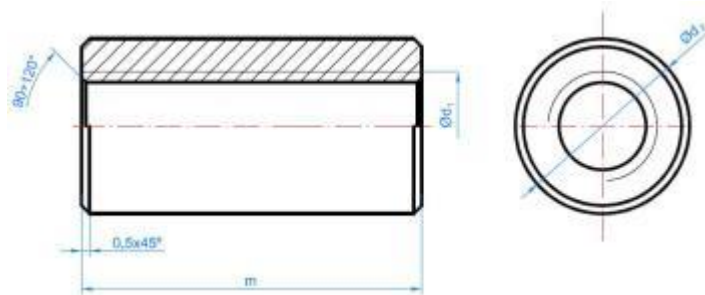

\*resistencia equivalente a un tornillo 6.8

**2.7 MARI**

**Manguito de conexión cilíndrico inoxidable\***



**Propiedades**



Acero inoxidable A2

**Dimensiones**

**Plano**

CODIGO		MARI0830	MARI1030
dφ: rosca	[mm]	M8	M10
m: longitud total	[mm]	30	30
φd2: diámetro exterior	[mm]	11	13
Varilla roscada		975A2M10	975A2M10

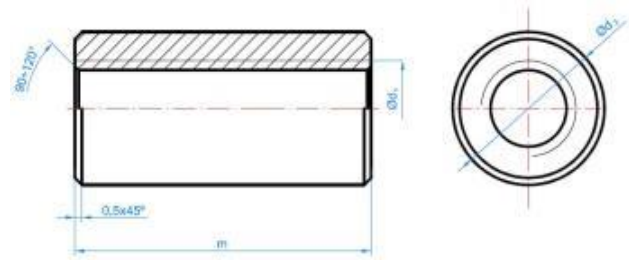

**2.8 PCU**

**Pletina de cuelgue**



**Propiedades**



Acero

Recubrimiento cincado

**Dimensiones**

**Plano**

CODIGO		PCU0005	PCU0006
dφ: rosca	[mm]	M8	M10
Varilla roscada		975ZM06	975ZM10

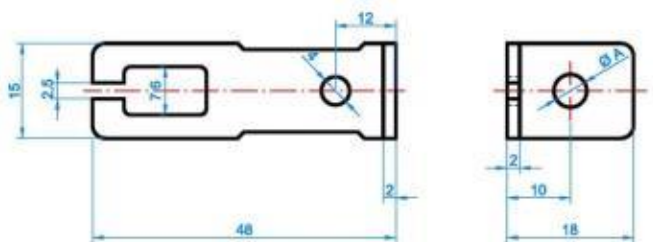

**2.9 ES-DR**

**Esparrago de doble rosca**



**Propiedades**



Acero

Recubrimiento cincado

**Dimensiones**

CODIGO	ØM	L1	ØD	L2	L3	SW	Huella
ESDR06040	M6	38,5 ÷ 40,5	5,75 ÷ 6,05	11 ÷ 13	23 ÷ 25	--	Hexalobular Tx15
ESDR06050		48,5 ÷ 50,5		15 ÷ 17	27 ÷ 30		
ESDR06060		58 ÷ 61		17 ÷ 19	33 ÷ 36		
ESDR06070		68 ÷ 71		25 ÷ 27			
ESDR06080		78 ÷ 81		33 ÷ 35			
ESDR08050	M8	48,5 ÷ 51	6,85 ÷ 7,15	12 ÷ 14	28 ÷ 31	--	Hexalobular Tx25
ESDR08060		58,5 ÷ 61		14 ÷ 16	36 ÷ 39		
ESDR08070		68,5 ÷ 71		24 ÷ 26			
ESDR08080		78 ÷ 81		27 ÷ 30			
ESDR08090		88 ÷ 91		46 ÷ 49	5,85 ÷ 6,00		
ESDR08100		98 ÷ 101					
ESDR08110		108 ÷ 111					
ESDR08120		118 ÷ 121					
ESDR08130	128 ÷ 131	48 ÷ 52					
ESDR10080	M10	78 ÷ 81	8,75 ÷ 9,15	16 ÷ 20	45 ÷ 48	7,85 ÷ 8,00	
ESDR10100		98 ÷ 101		22 ÷ 26	55 ÷ 59		
ESDR10110		108 ÷ 111		36 ÷ 40			
ESDR10120		118 ÷ 121		43 ÷ 47			
ESDR10130		128 ÷ 131		48 ÷ 52			
ESDR10140		138 ÷ 141					
ESDR10150		148 ÷ 151					
ESDR10180		178 ÷ 181					
ESDR10200		198 ÷ 201					

**PLANO**

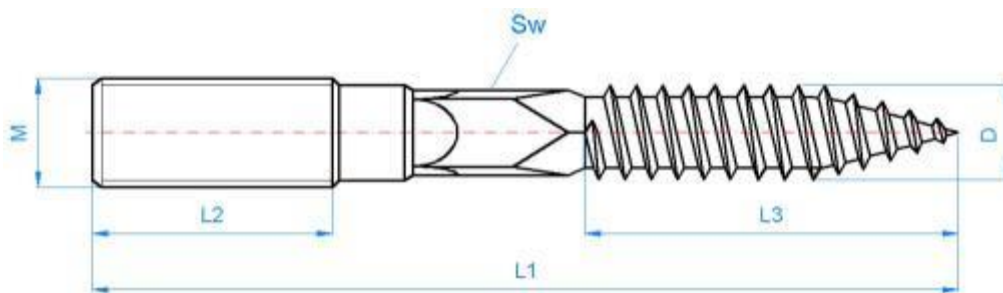

**2.10 ES-DA2**

**Esparrago de doble rosca inoxidable**

**Propiedades**



Acero inoxidable A2



**Dimensiones**

CODIGO	ØM	L1	ØD	L2	L3	SW	Huella
ESDA208060	M8	58,5 ÷ 61,5	6,85 ÷ 7,30	17,5 ÷ 22,5	28,95 ÷ 31,05	5,85 ÷ 6,00	--
ESDA210060	M10		8,75 ÷ 9,15			7,85 ÷ 8,00	

**PLANO**

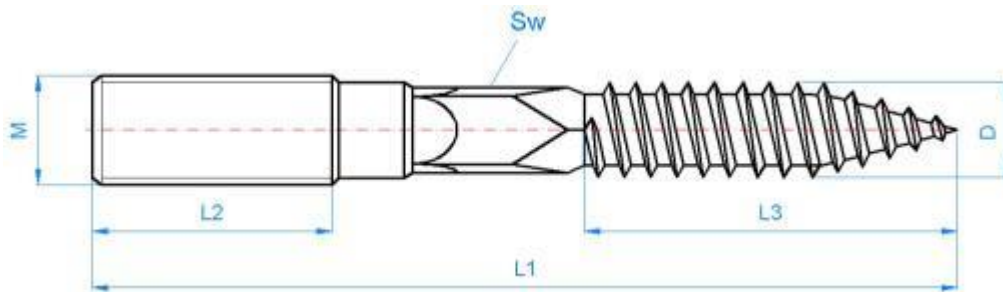

**2.11 AB-TA**

**Tirafondo abrazadera cincado**



**Propiedades**



Acero

Recubrimiento  
cincado

Huella  
Ranurada

**Dimensiones**

CODIGO	ØM	L1	ØD	L2	B	ØA	lg
ABTA0630	M6	28,95 ÷ 31,05	4,85 ÷ 5,15	5,8 ÷ 6,2	0,9 ÷ 1,1	8,0 ÷ 8,2	Completa
ABTA0640		38,75 ÷ 41,25					
ABTA0650		48,75 ÷ 51,25					
ABTA0730	M7	21÷23	5,5÷6,1	5,8 ÷ 6,2	0,8÷1,2	9,0÷10,0	Completa
ABTA0740		31÷33					
ABTA0750		41÷43					
ABTA0760		51÷53					
ABTA0770		61÷63					
ABTA0780	71÷73	45					
ABTA0840	M8	38,75 ÷ 41,25	5,85 ÷ 6,15	7,3 ÷ 7,7	1,3 ÷ 1,5	8,0 ÷ 8,3	Completa
ABTA0860		58,50 ÷ 61,50					45
ABTA0880		78,50 ÷ 81,50					45
ABTA1050	M10	48,50 ÷ 51,50	6,85 ÷ 7,15	8,8 ÷ 9,2	1,6 ÷ 1,8	12,0 ÷ 12,2	Completa
ABTA1070		68,50 ÷ 71,50					45
ABTA1090		<b>88,25 ÷ 91,75</b>					45

PLANO

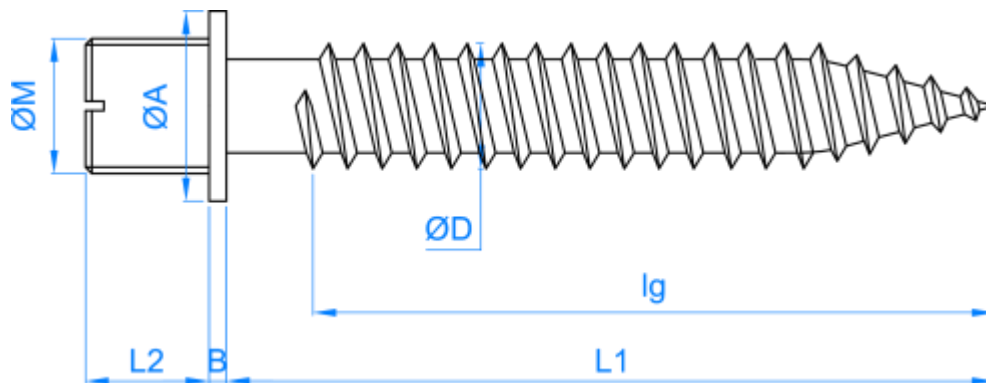

**2.12 AB-TA B**

**Tirafondo abrazadera bicromatado**



**Propiedades**



Acero

Bicromatado

Huella Ranurada

**Dimensiones**

CODIGO	ØM	L1	ØD	L2	B	ØA	lg
ABTA0630	M6	28,95 ÷ 31,05	4,85 ÷ 5,15	5,8 ÷ 6,2	0,9 ÷ 1,1	8,0 ÷ 8,2	Completa
ABTA0640		38,75 ÷ 41,25					
ABTA0650		48,75 ÷ 51,25					

**PLANO**

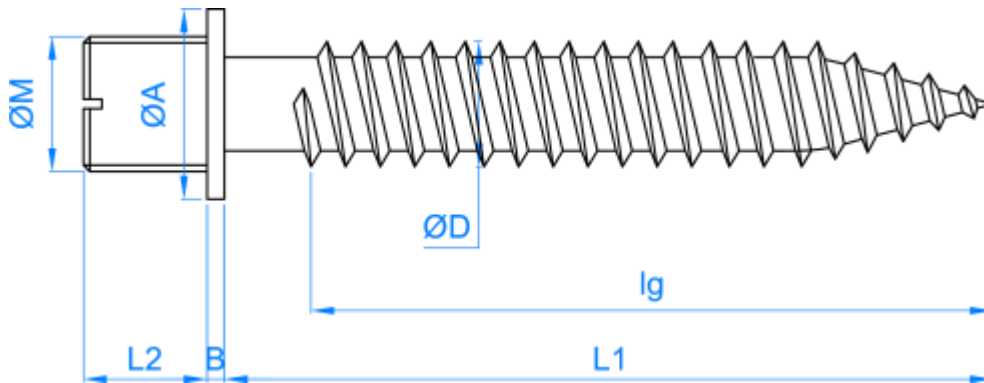

**2.13 AB-TA A2**

**Tirafondo abrazadera inoxidable A2**



**Propiedades**



Acero inoxidable A2

Huella Ranurada

**Dimensiones**

CODIGO	ØM	L1	ØD	L2	B	ØA	lg
ABTA20630	M6	28,95 ÷ 31,05	4,70 ÷ 5,20	6,8 ÷ 7,2	1,2	7,8	Completa

**PLANO**

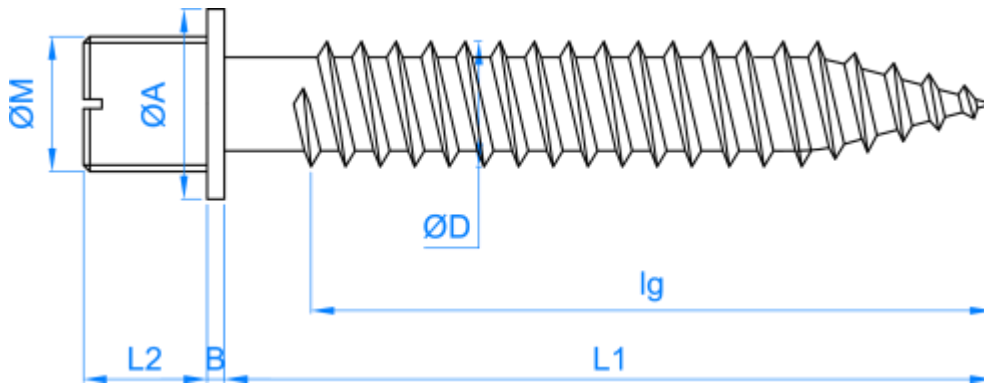



**2.14 AB-TG**

**Tirafondo grapa**



**Propiedades**



Acero

Recubrimiento  
cincado

Huella Pz +  
ranurada

**Dimensiones**

CODIGO	$\varnothing dk$	L	$\varnothing D$	p	Q	SW
ABTG4530	9,8	30	4,3	2,0	2,5	2
ABTG4535	9,8	35	4,3	2,0	2,5	2
ABTG4540	9,8	40	4,3	2,0	2,5	2
ABTG5030	11,8	30	4,8	2,2	2,7	3
ABTG5040	11,8	40	4,8	2,2	2,7	3

PLANO

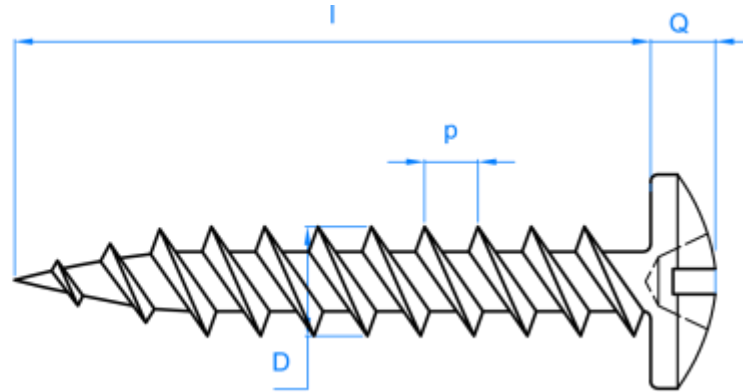
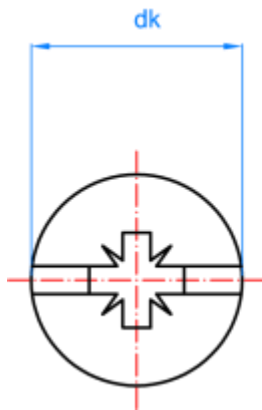

**2.15 PF-ZN**

**Pletina de fijación cincada**

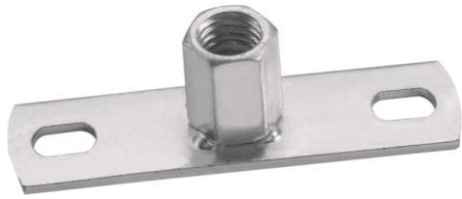

**Propiedades**



Acero

Recubrimiento cincado

**Dimensiones**

CODIGO	D1	D2	H	H1	H2
PFZNM0800	M8	--	7,5	7,5	--
PFZNM0810	M8	M10	17	7	10
PFZNM1000	--	M10	9	--	9

**PLANO**

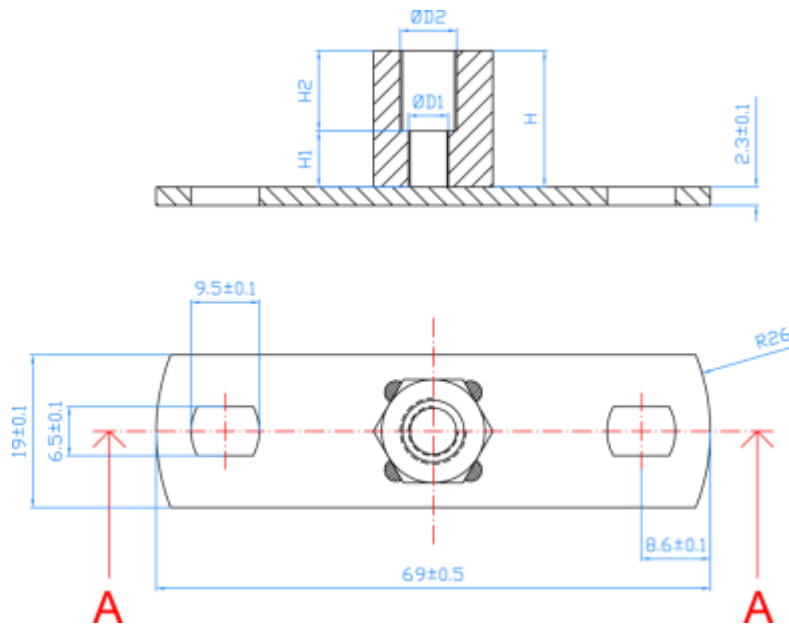

2.16

PF-A4

Pletina de fijación inoxidable A4



Propiedades



Acero inoxidable A4

Dimensiones

CODIGO	D1	D2	H	H1	H2
PFA4M0800	M8	--	7,5	7,5	--
PFA4M0810	M8	M10	17	7	10
PFA4M1000	--	M10	9	--	9

PLANO

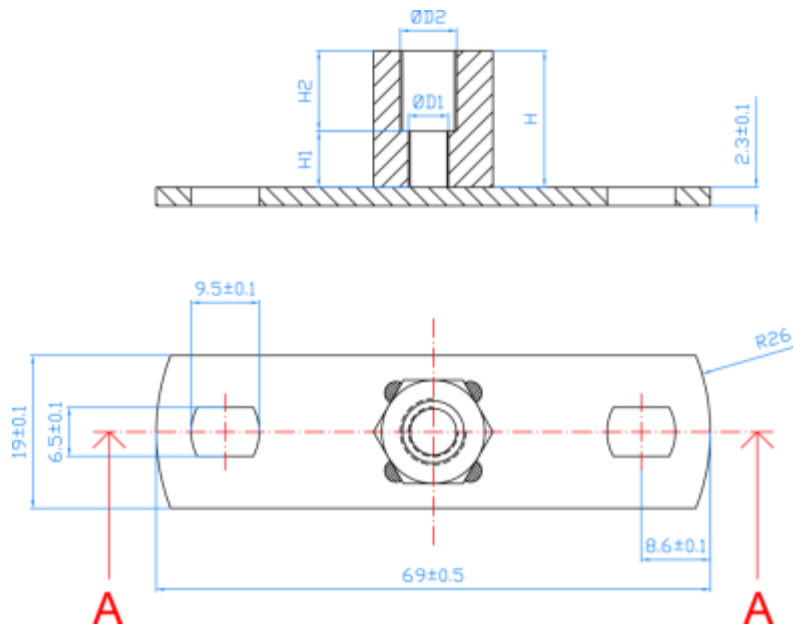

**2.17 AB-TR**

**Tornillo doble para abrazaderas**



**Propiedades**



Acero

Recubrimiento cincado

**Dimensiones**

CODIGO	MA	MB	L1	L2	k	Ødk
ABTR05030	M7	M5	30	6	1	9
ABTR05040	M7	M5	40	6	1	9
ABTR05050	M7	M5	50	6	1	9
ABTR05060	M7	M5	60	6	1	9
ABTR06040	M7	M6	40	6	1	9
ABTR06050	M7	M6	50	6	1	9
ABTR06060	M7	M6	60	6	1	9

**PLANO**

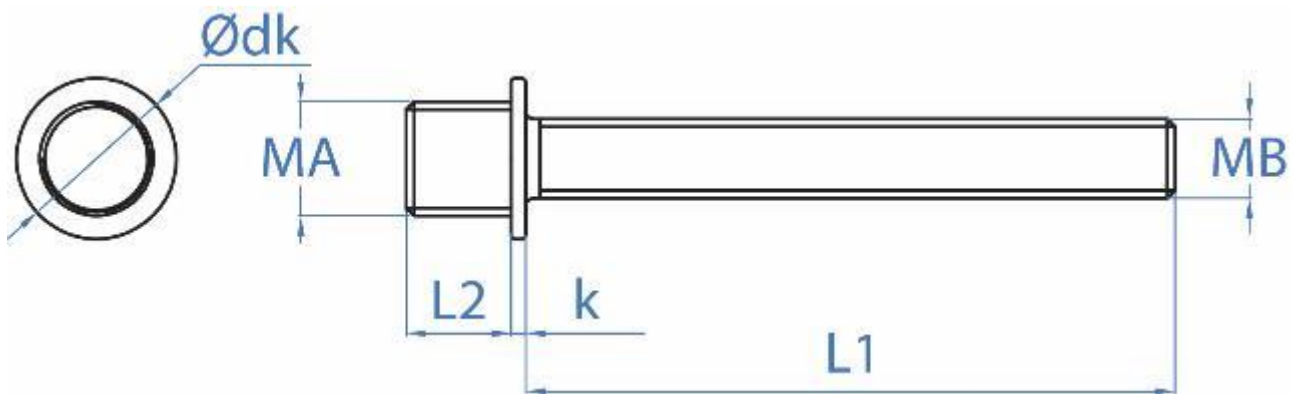

**2.18 AB-FP**

**Florón plano para abrazaderas**



**Propiedades**



Acero



Recubrimiento cincado

**Dimensiones**

CODIGO	$\varnothing D$	$\varnothing d$	H
ABFP25	25	7	3
ABFP32	32	7	4

**PLANO**

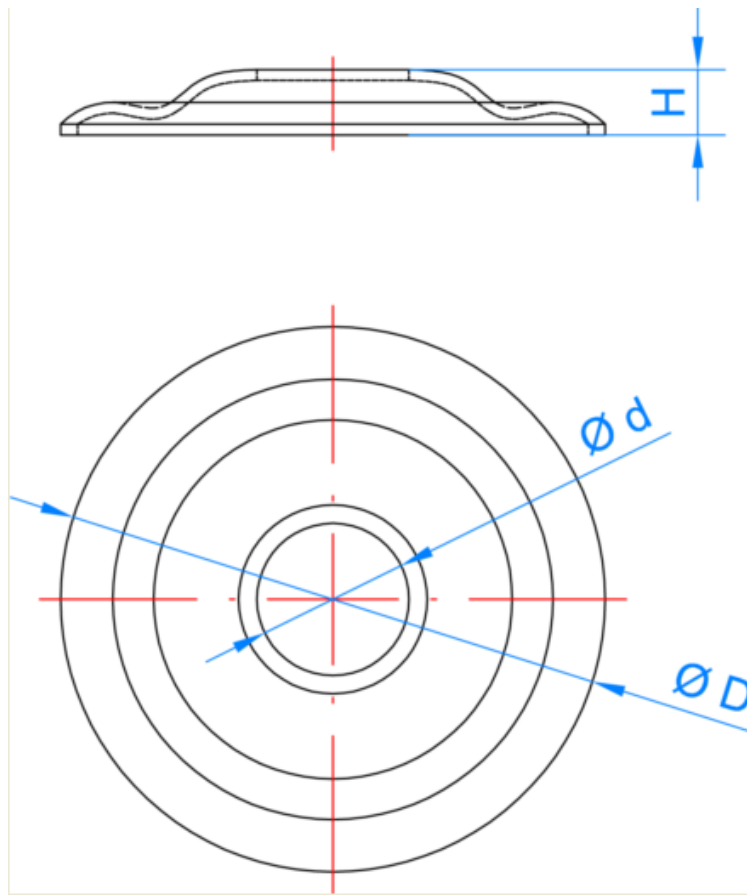

**2.19 AB-FC**

**Florón cónico para abrazaderas**



**Propiedades**



Acero

Recubrimiento cincado

**Dimensiones**

CODIGO	$\varnothing d$	$\varnothing D$	H
ABFC09	7	26	9
ABFC14	7	30	14
ABFC19	7	34	19

**PLANO**

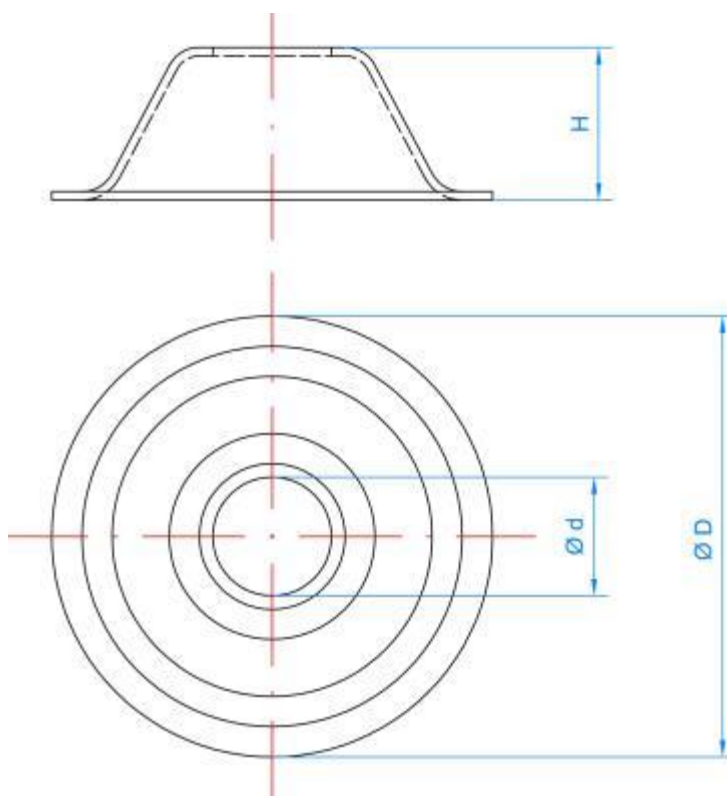

**2.20 AB-PM7**

**Prolongador cilíndrico para abrazaderas M7**



**Propiedades**



Acero



Recubrimiento cincado

**Dimensiones**

CODIGO	A	B	C
ABPM720	20	8	11
ABPM730	30	8	12
ABPM740	40	8	13

**PLANO**

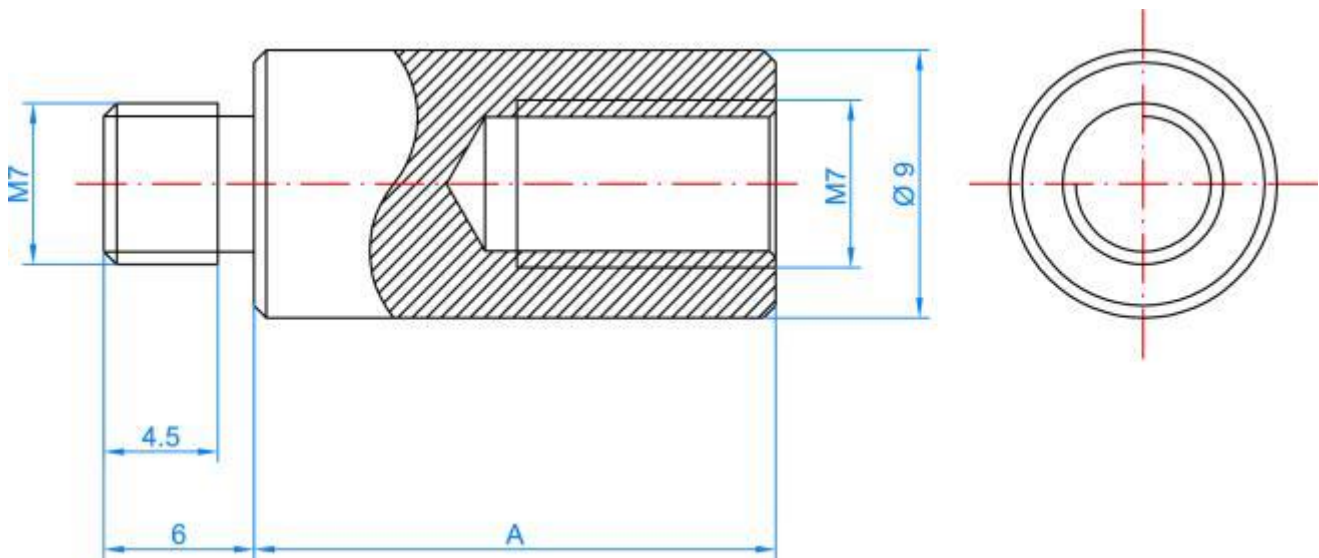



2.21

TM-VR

Tornillo manguito para varilla roscada



Propiedades



Acero



Recubrimiento cincado

Dimensiones

CODIGO	M	L	L1
TMVR06065	M6	65	50
TMVR07065	M7	65	50
TMVR08065	M8	65	50

PLANO

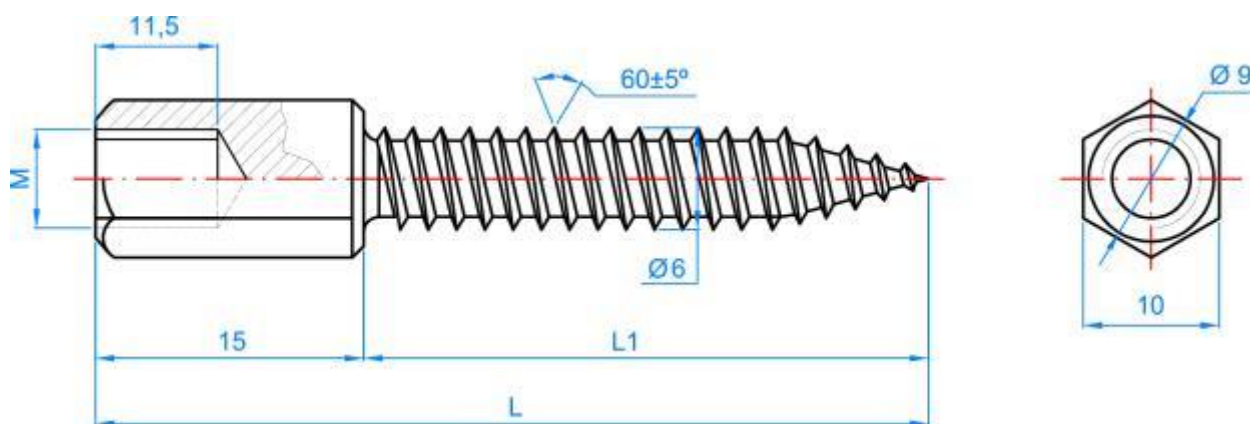

**2.22 MAMH**

**Manguito separador macho/hembra**



**Propiedades**



Acero



Recubrimiento cincado

**Dimensiones**

CODIGO	A	B	L	SW
MAMH0610	8	8	10	10
MAMH0620	10	12	20	10
MAMH0630	10	18	30	10
MAMH0640	10	18	40	10
MAMH0650	10	18	50	10

**PLANO**

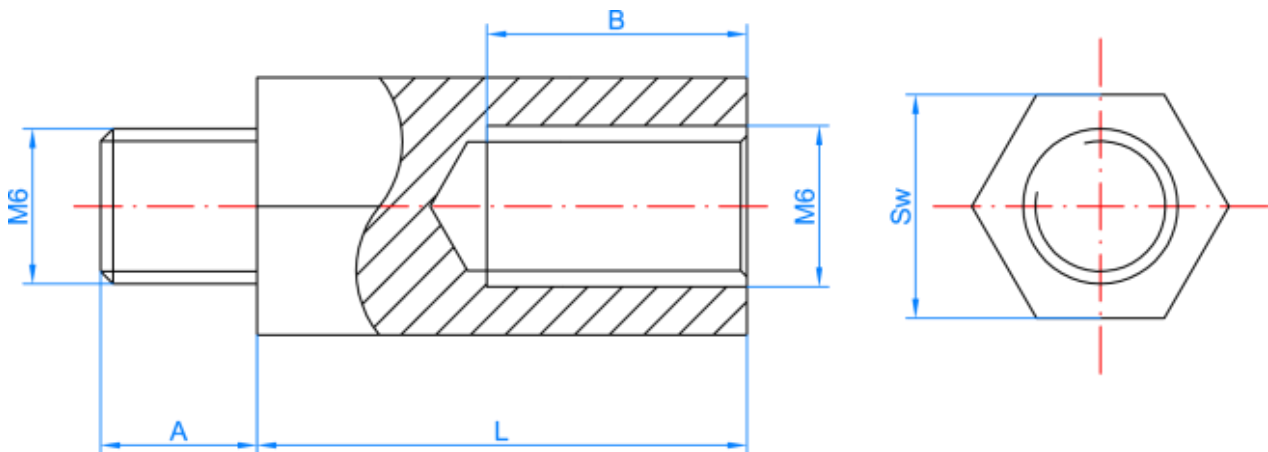

**2.23 UN-CO**

**Unión conducto tipo C**



**Propiedades**



Acero

Recubrimiento cincado

**Dimensiones**

CODIGO	A	B	C	E	M	SW
UNCO3220	27,5	2,75	30	22	M8	10

**PLANO**

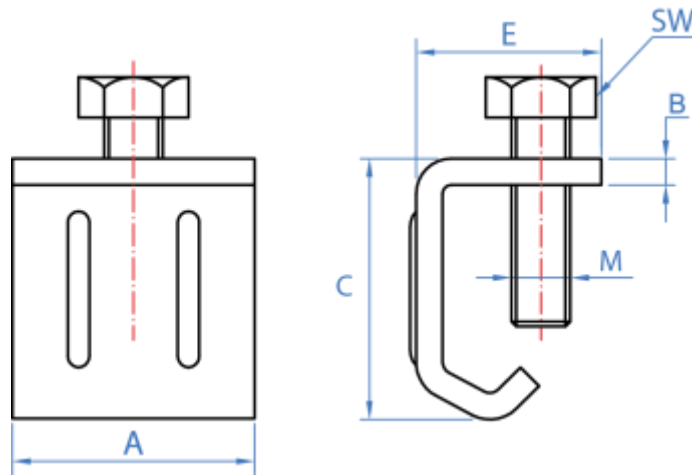

**2.24 CO-AR**

**Colgador articulado**

**Propiedades**



Acero



Recubrimiento cincado

**Dimensiones**

CODIGO	ØM (mm)	ØM1 (mm)	L1	Sw	Sw2
COAR08060	M8	M8	60	12,8 – 12,9	14,8 -14,9
COAR10060	M10	M10	61	16,8 – 16,9	16,8 – 16,9

**PLANO**

